

CHELSEA[®]

277/278 Series Crossover to 280 Series

Effective: January 15, 2014

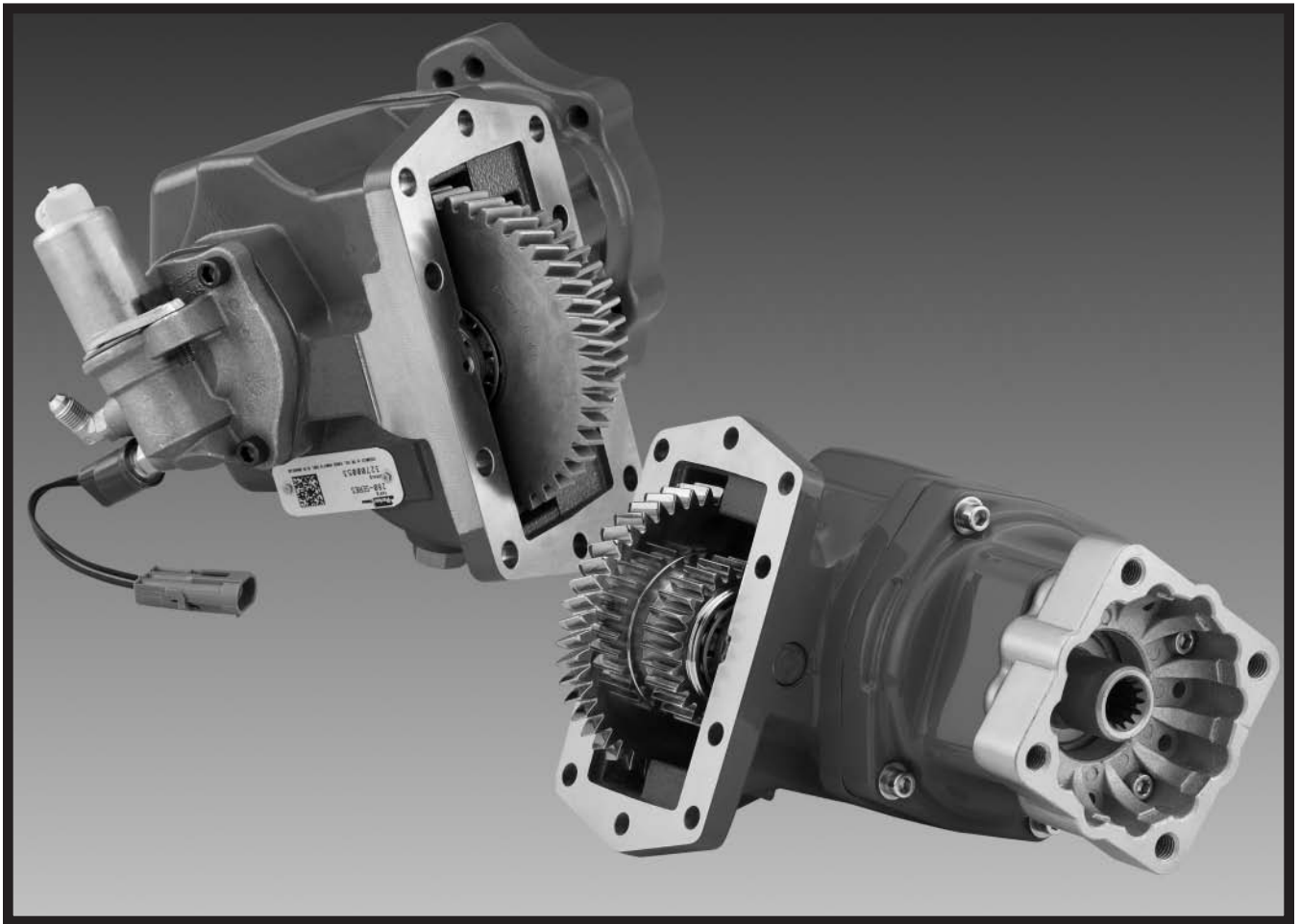

277 Series Crossover to 280 Series

INPUT AND RATIO OPTIONS

OLD SERIES "FJ" PITCH	INTERNAL RATIO	INPUT GEAR	NEW SERIES	INTERNAL RATIO	INPUT GEAR	RATIO GEAR	INPUT KIT NUMBER
			280GBFJ*-.5**	22/50	5-P-1491	5-P-1478	5-P-1491-1X
277XBFJ*-.5**	25/47	5-P-912	280GCFJ*-.5**	25/47	5-P-1491	5-P-1495	5-P-1491-2X
277XDFJ*-.5**	28/44	5-P-913	280GDFJ*-.5**	28/44	5-P-1491	5-P-1479	5-P-1491-3X
277XGFJ*-.5**	31/41	5-P-914	280GGFJ*-.5**	31/41	5-P-1491	5-P-1480	5-P-1491-4X
			280GKFJ*-.5**	33/39	5-P-1491	5-P-1481	5-P-1491-5X
277XMFJ*-.5**	35/37	5-P-915	280GMFJ*-.5**	35/37	5-P-1491	5-P-1482	5-P-1491-6X
			280GPFJ*-.5**	37/35	5-P-1491	5-P-1483	5-P-1491-7X
277XSFJ*-.5**	39/33	5-P-1173	280GSFJ*-.5**	39/33	5-P-1491	5-P-1484	5-P-1491-8X
			280GTFJ*-.5**	41/31	5-P-1491	5-P-1497	5-P-1491-9X
			280GBFJ*-.5**	22/50	5-P-1491	5-P-1478	5-P-1491-1X
277SBFJ*-.5**	25/47	5-P-1350	280GCFJ*-.5**	25/47	5-P-1491	5-P-1495	5-P-1491-2X
277SDFJ*-.5**	28/44	5-P-1293	280GDFJ*-.5**	28/44	5-P-1491	5-P-1479	5-P-1491-3X
277SGFJ*-.5**	31/41	5-P-1225	280GGFJ*-.5**	31/41	5-P-1491	5-P-1480	5-P-1491-4X
			280GKFJ*-.5**	33/39	5-P-1491	5-P-1481	5-P-1491-5X
277SMFJ*-.5**	35/37	5-P-1351	280GMFJ*-.5**	35/37	5-P-1491	5-P-1482	5-P-1491-6X
			280GPFJ*-.5**	37/35	5-P-1491	5-P-1483	5-P-1491-7X
277SSFJ*-.5**	39/33	5-P-1173	280GSFJ*-.5**	39/33	5-P-1491	5-P-1484	5-P-1491-8X
			280GTFJ*-.5**	41/31	5-P-1491	5-P-1497	5-P-1491-9X
			280GBFJ*-.3**	22/50	5-P-1491	5-P-1478	5-P-1491-1X
277HBFJ*-.3**	25/47	5-P-1350	280GCFJ*-.3**	25/47	5-P-1491	5-P-1495	5-P-1491-2X
277HDFJ*-.3**	28/44	5-P-1293	280GDFJ*-.3**	28/44	5-P-1491	5-P-1479	5-P-1491-3X
277HGFJ*-.3**	31/41	5-P-1225	280GGFJ*-.3**	31/41	5-P-1491	5-P-1480	5-P-1491-4X
			280GKFJ*-.3**	33/39	5-P-1491	5-P-1481	5-P-1491-5X
277HMFJ*-.3**	35/37	5-P-1351	280GMFJ*-.3**	35/37	5-P-1491	5-P-1482	5-P-1491-6X
			280GPFJ*-.3**	37/35	5-P-1491	5-P-1483	5-P-1491-7X
277HHFJ*-.3**	39/33	5-P-1173	280GSFJ*-.3**	39/33	5-P-1491	5-P-1484	5-P-1491-8X
			280GTFJ*-.3**	41/31	5-P-1491	5-P-1497	5-P-1491-9X
			280GBFJ*-.3**	22/50	5-P-1491	5-P-1478	5-P-1491-1X
277KBFJ*-.3**	25/47	5-P-1350	280GCFJ*-.3**	25/47	5-P-1491	5-P-1495	5-P-1491-2X
277KDFJ*-.3**	28/44	5-P-1293	280GDFJ*-.3**	28/44	5-P-1491	5-P-1479	5-P-1491-3X
277KGFJ*-.3**	31/41	5-P-1225	280GGFJ*-.3**	31/41	5-P-1491	5-P-1480	5-P-1491-4X
			280GKFJ*-.3**	33/39	5-P-1491	5-P-1481	5-P-1491-5X
277KMFJ*-.3**	35/37	5-P-1351	280GMFJ*-.3**	35/37	5-P-1491	5-P-1482	5-P-1491-6X
			280GPFJ*-.3**	37/35	5-P-1491	5-P-1483	5-P-1491-7X
277KHFJ*-.3**	39/33	5-P-1173	280GSFJ*-.3**	39/33	5-P-1491	5-P-1484	5-P-1491-8X
			280GTFJ*-.3**	41/31	5-P-1491	5-P-1497	5-P-1491-9X

277 Series Crossover to 280 Series

INPUT AND RATIO OPTIONS

OLD SERIES "KV" PITCH	INTERNAL RATIO	INPUT GEAR	NEW SERIES	INTERNAL RATIO	INPUT GEAR	RATIO GEAR	INPUT KIT NUMBER
			280GBKV*-*5**	22/50	5-P-1493	5-P-1478	5-P-1493-1X
277XBKV*-*5**	25/47	5-P-1361	280GCKV*-*5**	25/47	5-P-1493	5-P-1495	5-P-1493-2X
277XDKV*-*5**	28/44	5-P-1362	280GDKV*-*5**	28/44	5-P-1493	5-P-1479	5-P-1493-3X
277XGKV*-*5**	31/41	5-P-1363	280GGKV*-*5**	31/41	5-P-1493	5-P-1480	5-P-1493-4X
			280GKKV*-*5**	33/39	5-P-1493	5-P-1481	5-P-1493-5X
277XMKV*-*5**	35/37	5-P-1367	280GMKV*-*5**	35/37	5-P-1493	5-P-1482	5-P-1493-6X
			280GPKV*-*5**	37/35	5-P-1493	5-P-1483	5-P-1493-7X
277XSKV*-*5**	39/33	5-P-1369	280GSKV*-*5**	39/33	5-P-1493	5-P-1484	5-P-1493-8X
			280GTKV*-*5**	41/31	5-P-1493	5-P-1497	5-P-1493-9X
			280GBKV*-*5**	22/50	5-P-1493	5-P-1478	5-P-1493-1X
277SBKV*-*5**	25/47	5-P-1402	280GCKV*-*5**	25/47	5-P-1493	5-P-1495	5-P-1493-2X
277SDKV*-*5**	28/44	5-P-1413	280GDKV*-*5**	28/44	5-P-1493	5-P-1479	5-P-1493-3X
277SGKV*-*5**	31/41	5-P-1414	280GGKV*-*5**	31/41	5-P-1493	5-P-1480	5-P-1493-4X
			280GKKV*-*5**	33/39	5-P-1493	5-P-1481	5-P-1493-5X
277SMKV*-*5**	35/37	5-P-1415	280GMKV*-*5**	35/37	5-P-1493	5-P-1482	5-P-1493-6X
			280GPKV*-*5**	37/35	5-P-1493	5-P-1483	5-P-1493-7X
277SSKV*-*5**	39/33	5-P-1416	280GSKV*-*5**	39/33	5-P-1493	5-P-1484	5-P-1493-8X
			280GTKV*-*5**	41/31	5-P-1493	5-P-1497	5-P-1493-9X
			280GBKV*-*3**	22/50	5-P-1493	5-P-1478	5-P-1493-1X
277HBKV*-*3**	25/47	5-P-1361	280GCKV*-*3**	25/47	5-P-1493	5-P-1495	5-P-1493-2X
277HDKV*-*3**	28/44	5-P-1362	280GDKV*-*3**	28/44	5-P-1493	5-P-1479	5-P-1493-3X
277HGKV*-*3**	31/41	5-P-1363	280GGKV*-*3**	31/41	5-P-1493	5-P-1480	5-P-1493-4X
			280GKKV*-*3**	33/39	5-P-1493	5-P-1481	5-P-1493-5X
277HMKV*-*3**	35/37	5-P-1367	280GMKV*-*3**	35/37	5-P-1493	5-P-1482	5-P-1493-6X
			280GPKV*-*3**	37/35	5-P-1493	5-P-1483	5-P-1493-7X
277HHKV*-*3**	39/33	5-P-1369	280GSKV*-*3**	39/33	5-P-1493	5-P-1484	5-P-1493-8X
			280GTKV*-*3**	41/31	5-P-1493	5-P-1497	5-P-1493-9X
			280GBKV*-*3**	22/50	5-P-1493	5-P-1478	5-P-1493-1X
277KBKV*-*3**	25/47	5-P-1361	280GCKV*-*3**	25/47	5-P-1493	5-P-1495	5-P-1493-2X
277KDKV*-*3**	28/44	5-P-1362	280GDKV*-*3**	28/44	5-P-1493	5-P-1479	5-P-1493-3X
277KGV*-*3**	31/41	5-P-1363	280GGKV*-*3**	31/41	5-P-1493	5-P-1480	5-P-1493-4X
			280GKKV*-*3**	33/39	5-P-1493	5-P-1481	5-P-1493-5X
277KMKV*-*3**	35/37	5-P-1367	280GMKV*-*3**	35/37	5-P-1493	5-P-1482	5-P-1493-6X
			280GPKV*-*3**	37/35	5-P-1493	5-P-1483	5-P-1493-7X
277KHKV*-*3**	39/33	5-P-1369	280GSKV*-*3**	39/33	5-P-1493	5-P-1484	5-P-1493-8X
			280GTKV*-*3**	41/31	5-P-1493	5-P-1497	5-P-1493-9X

278 Series Crossover to 280 Series

INPUT AND RATIO OPTIONS

OLD SERIES "FJ" PITCH	INTERNAL RATIO	INPUT GEAR	NEW SERIES	INTERNAL RATIO	INPUT GEAR	RATIO GEAR	INPUT KIT NUMBER
			280GBFJ*-*8**	22/53	5-P-1491	5-P-1478	5-P-1491-1X
278XBFJ*-*3**	25/50	5-P-912	280GCFJ*-*8**	25/50	5-P-1491	5-P-1495	5-P-1491-2X
278XDFJ*-*3**	28/47	5-P-913	280GDFJ*-*8**	28/47	5-P-1491	5-P-1479	5-P-1491-3X
278XGFJ*-*3**	31/44	5-P-914	280GGFJ*-*8**	31/44	5-P-1491	5-P-1480	5-P-1491-4X
278XMFJ*-*3**	35/40	5-P-915	280GMFJ*-*8**	35/40	5-P-1491	5-P-1482	5-P-1491-6X
278XPFJ*-*3**	36/39	5-P-1173	280GPFJ*-*8**	37/38	5-P-1491	5-P-1483	5-P-1491-7X
278XSFJ*-*3**	39/36	5-P-1409	280GSFJ*-*8**	39/36	5-P-1491	5-P-1484	5-P-1491-8X
278XTFJ*-*3**	42/33	5-P-1390	280GTFJ*-*8**	42/33	5-P-1491	5-P-1485	5-P-1491-10X
			280GBFJ*-*8**	22/53	5-P-1491	5-P-1478	5-P-1491-1X
278SBFJ*-*3**	25/50	5-P-1350	280GCFJ*-*8**	25/50	5-P-1491	5-P-1495	5-P-1491-2X
278SDFJ*-*3**	28/47	5-P-1293	280GDFJ*-*8**	28/47	5-P-1491	5-P-1479	5-P-1491-3X
278SGFJ*-*3**	31/44	5-P-1225	280GGFJ*-*8**	31/44	5-P-1491	5-P-1480	5-P-1491-4X
278SMFJ*-*3**	35/40	5-P-1351	280GMFJ*-*8**	35/40	5-P-1491	5-P-1482	5-P-1491-6X
278SPFJ*-*3**	36/39	5-P-1477	280GPFJ*-*8**	37/38	5-P-1491	5-P-1483	5-P-1491-7X
278SSFJ*-*3**	39/36	5-P-1173	280GSFJ*-*8**	39/36	5-P-1491	5-P-1484	5-P-1491-8X
278STFJ*-*3**	42/33	5-P-1410	280GTFJ*-*8**	42/33	5-P-1491	5-P-1485	5-P-1491-10X

278 Series Crossover to 280 Series

INPUT AND RATIO OPTIONS

OLD SERIES "KV" PITCH	INTERNAL RATIO	INPUT GEAR	NEW SERIES	INTERNAL RATIO	INPUT GEAR	RATIO GEAR	INPUT KIT NUMBER
			280GBKV*-*8**	22/53	5-P-1493	5-P-1478	5-P-1493-1X
278XBKV*-*3**	25/50	5-P-1361	280GCKV*-*8**	25/50	5-P-1493	5-P-1495	5-P-1493-2X
278XDKV*-*3**	28/47	5-P-1362	280GDKV*-*8**	28/47	5-P-1493	5-P-1479	5-P-1493-3X
278XGKV*-*3**	31/44	5-P-1363	280GGKV*-*8**	31/44	5-P-1493	5-P-1480	5-P-1493-4X
278XMKV*-*3**	35/40	5-P-1367	280GMKV*-*8**	35/40	5-P-1493	5-P-1482	5-P-1493-6X
			280GPKV*-*8**	37/38	5-P-1493	5-P-1483	5-P-1493-7X
278XSKV*-*3**	39/36	5-P-1369	280GSKV*-*8**	39/36	5-P-1493	5-P-1484	5-P-1493-8X
			280GTKV*-*8**	42/33	5-P-1493	5-P-1485	5-P-1493-10X
			280GBKV*-*8**	22/53	5-P-1493	5-P-1478	5-P-1493-1X
278SBKV*-*3**	25/50	5-P-1402	280GCKV*-*8**	25/50	5-P-1493	5-P-1495	5-P-1493-2X
278SDKV*-*3**	28/47	5-P-1413	280GDKV*-*8**	28/47	5-P-1493	5-P-1479	5-P-1493-3X
278SGKV*-*3**	31/44	5-P-1414	280GGKV*-*8**	31/44	5-P-1493	5-P-1480	5-P-1493-4X
278SMKV*-*3**	35/40	5-P-1415	280GMKV*-*8**	35/40	5-P-1493	5-P-1482	5-P-1493-6X
			280GPKV*-*8**	37/38	5-P-1493	5-P-1483	5-P-1493-7X
278SSKV*-*3**	39/36	5-P-1416	280GSKV*-*8**	39/36	5-P-1493	5-P-1484	5-P-1493-8X
			280GTKV*-*8**	42/33	5-P-1493	5-P-1485	5-P-1493-10X

277/278 Series Crossover to 280 Series

OUTPUT OPTIONS

OLD SERIES	NEW SERIES	DESCRIPTION
277/278-**AB	280-**AB	DIN 120 Flange
277/278-**AC	280-**AC	DIN 100 Flange
277/278-**AF	280-**RF	Rotatable SAE "BB" Shaft / SAE "B" Pilot
277/278-**BA	280-**BD	Shaft Brake with 1.25" Keyway
	280-**BA	Shaft Brake with 1410 Flange
277/278-**G220	Not Available	RA Output with G102-1-2.0 R-4S-AS Pump
277/278-**PA	Not Available	Rotatable SAE "B" Shaft / SAE "B" Pilot
277/278-**PF	Not Available	Rotatable SAE "BB" Shaft / SAE "B" Pilot
277/278-**RA	280-**RK	2 & 4 Bolt Rotatable SAE "B" Shaft / SAE "B" Pilot
277/278-**RB	280-**RK	2 & 4 Bolt Rotatable SAE "B" Shaft / SAE "B" Pilot
277/278-**RF	280-**RF	2 & 4 Bolt Rotatable SAE "BB" Shaft / SAE "B" Pilot
277/278-**RG	280-**RF	2 & 4 Bolt Rotatable SAE "BB" Shaft / SAE "B" Pilot
277/278-**RK	280-**RK	2 & 4 Bolt Rotatable SAE "B" Shaft / SAE "B" Pilot
277/278-**RM	280-**RF	2 & 4 Bolt Rotatable SAE "BB" Shaft / SAE "B" Pilot
277/278-**XD	280-**XD	1-1/4" Round Shaft with Keyway
277/278-**XE	Not Available	SAE "A" Shaft / SAE "A" Pilot
277/278-**XK	280-**RK	Rotatable SAE "B" Shaft / SAE "B" Pilot
277/278-**XP	Not Available	Special SAE "B" Shaft/SAE "A" Pilot
277/278-**XR	Not Available	Non-Standard Flange
277/278-**XV	280-**XV	1-1/2" 10T Spline Shaft with 1410 Flange
277/278-**XX	280-**XV	1-1/2" 10T Spline Shaft with 1410 Flange
277/278-**XY	280-**RY	Rotatable DIN 5462 Flange / DIN 5462 (B8x32x36)
277/278-**ZY	280-**RY	Rotatable DIN 5462 Flange / DIN 5462 (B8x32x36)
	280-**RS	2 & 4 Bolt Rotatable SAE "C" Shaft / Pilot
	280-**RZ	2 & 4 Bolt Rotatable SAE "C" Shaft / SAE "B" Pilot
	280-**UN	UNI 8953 3-Bolt Flange / DIN 5462 (B6x23x26)

277/278 Series Crossover to 280 Series

SHIFT OPTIONS

OLD SERIES	NEW SERIES	DESCRIPTION
277/278-B	280-B	12V Hydraulic
277/278-D	280-D	24V Hydraulic
277/278-G	280-G	12V Remote w/o EOC
277/278-H	280-H	24V Remote w/o EOC
277/278-K	280-K	12V Hydraulic w/ EOC
277/278-L	280-L	24V Hydraulic w/ EOC
277/278-M	280-M	12V w/o Installation Kit 329024-12X
277/278-N	280-N	24V w/o Installation Kit 329024-24X
277/278-S	280-S	Air Shift with PTO/Dump Pump Combo Valve
277/278-T	280-T	Air Shift with PTO/Dump Pump Combo Valve
277/278-F	Not Available	ENGLAND ONLY - Remote 24V

277/278 Series Crossover to 280 Series

LUBRICATION OPTIONS

OLD SERIES	NEW SERIES	DESCRIPTION
277/278-P	280-P	Pressure Lube Only
277/278-R	280-R	Valve Cap Rotated 120 Degrees
	280-S	Valve Cap Rotated 240 Degrees
277/278-W	280-W	Wet Spline
277/278-V	280-V	Valve Cap Rotated 120 Degrees Wet Spline
	280-Y	Valve Cap Rotated 240 Degrees Wet Spline



Parker Hannifin Corporation
Chelsea Products Division
8225 Hacks Cross Road
Olive Branch, Mississippi 38654 USA
Tel: (662) 895-1011
Fax: (662) 895-1069
www.parker.com/chelsea
HY25-0182-B1/US

