

CHELSEA®

Bulletin HY25-2901-M1/US

Parts List 901 Series

Effective: January 15, 2002
Supersedes: P410-901 Dated June 1985

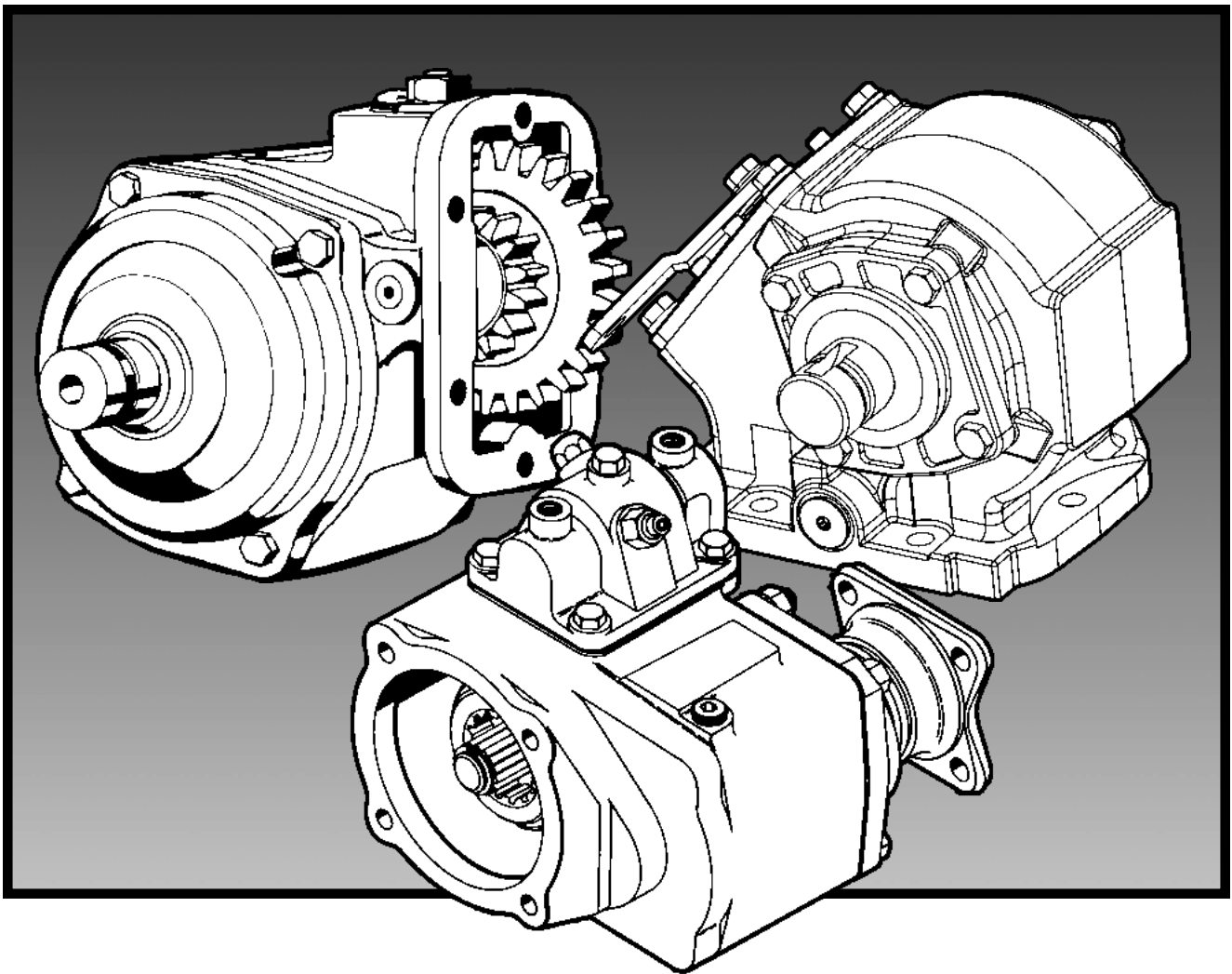

Parker
Hydraulics

 **WARNING**

FAILURE OR IMPROPER SELECTION OR IMPROPER USE OF THE PRODUCTS AND/OR SYSTEMS DESCRIBED HEREIN OR RELATED ITEMS CAN CAUSE DEATH, PERSONAL INJURY AND PROPERTY DAMAGE.

This document and other information from Parker Hannifin Corporation, its subsidiaries and authorized distributors provide product and/or system options for further investigation by users having technical expertise. It is important that you analyze all aspects of your application and review the information concerning the product or system in the current product catalog. Due to the variety of operating conditions and applications for these products or systems, the user, through its own analysis and testing, is solely responsible for making the final selection of the products and systems and assuring that all performance, safety and warning requirements of the application are met.

The products described herein, including without limitation, product features, specifications, designs, availability and pricing, are subject to change by Parker Hannifin Corporation and its subsidiaries at any time without notice.

Offer of Sale

The items described in this document are hereby offered for sale by Parker Hannifin Corporation, its subsidiaries or its authorized distributors. This offer and its acceptance are governed by the provisions stated in the "Offer of Sale".

© Copyright 2002, Parker Hannifin Corporation, All Rights Reserved

Contents

Cross Sectional View	1
End View - P.T.O. Output	2
End View	3
Bill of Materials	4-5
Air Control	6
Pump Assemblies	7-8
Model Number Designation	9
Assembly Arrangements	9
Shifter Arrangements	9
Offer of Sale	12

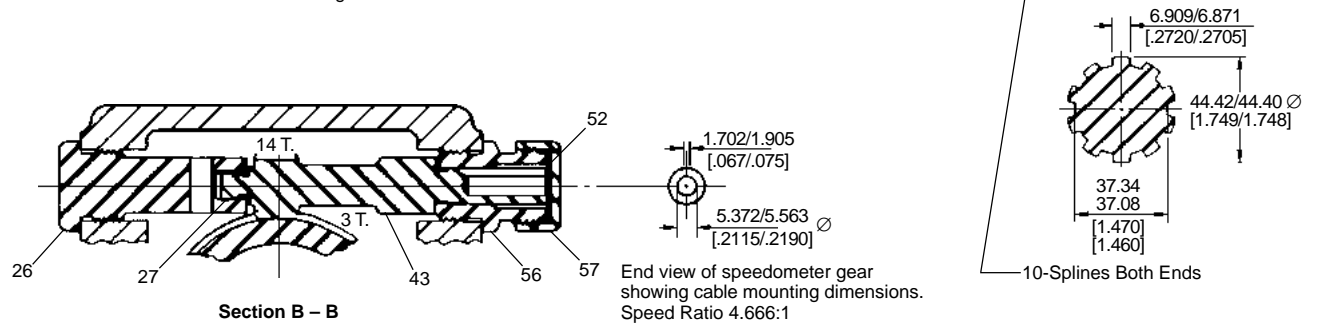
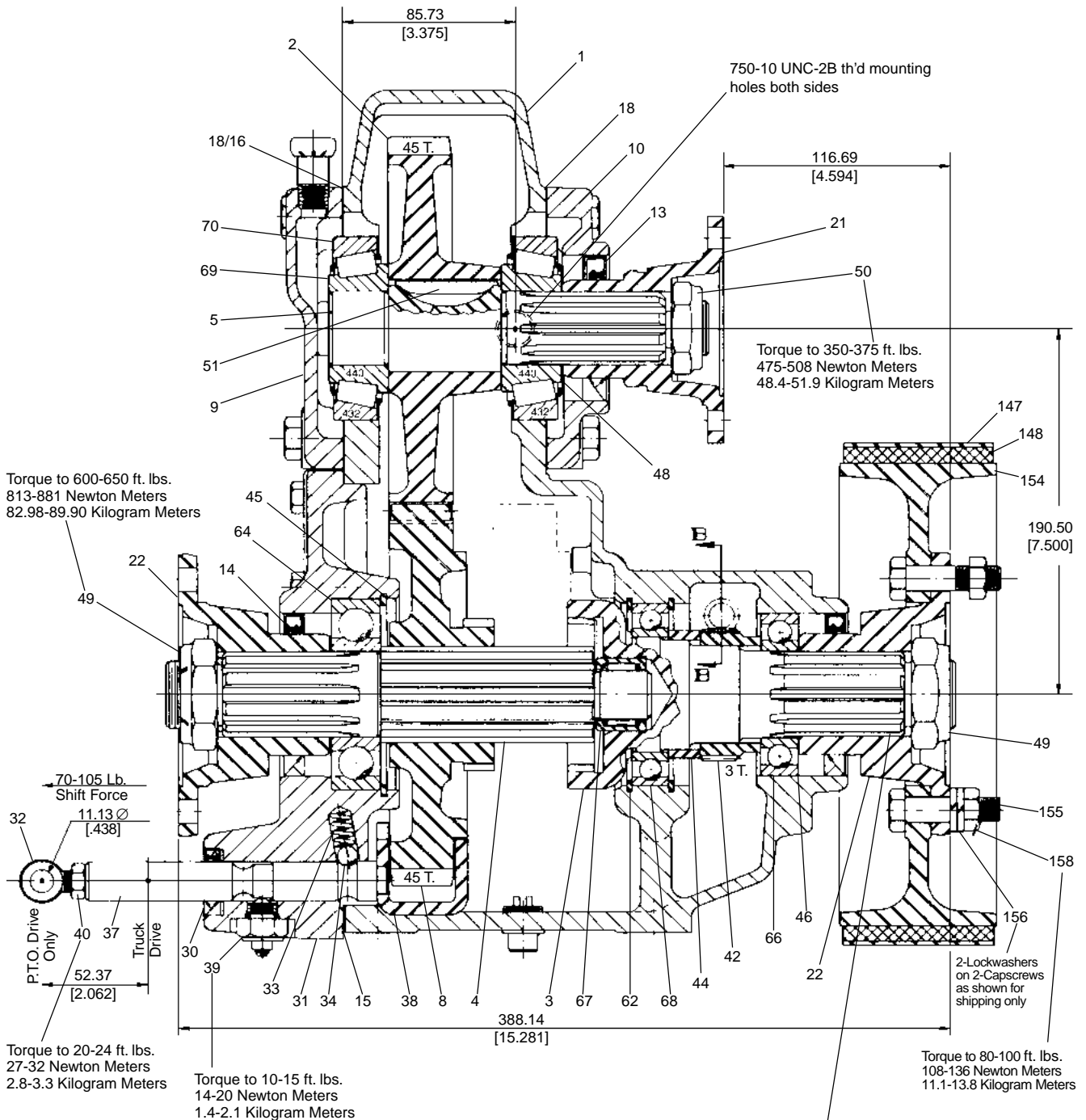

Speedometer output may be mounted right or left, depending on direction of rotation required.

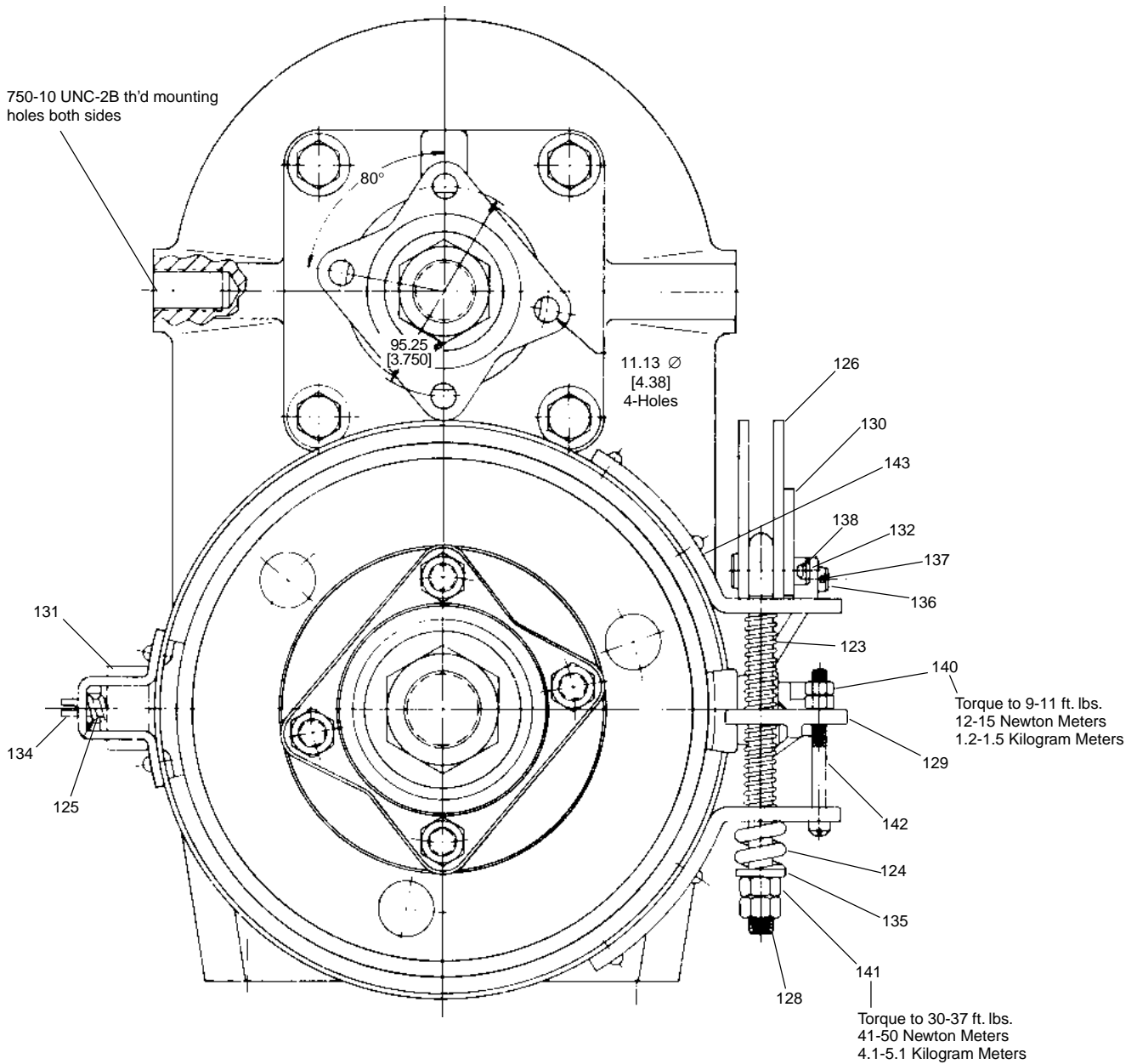

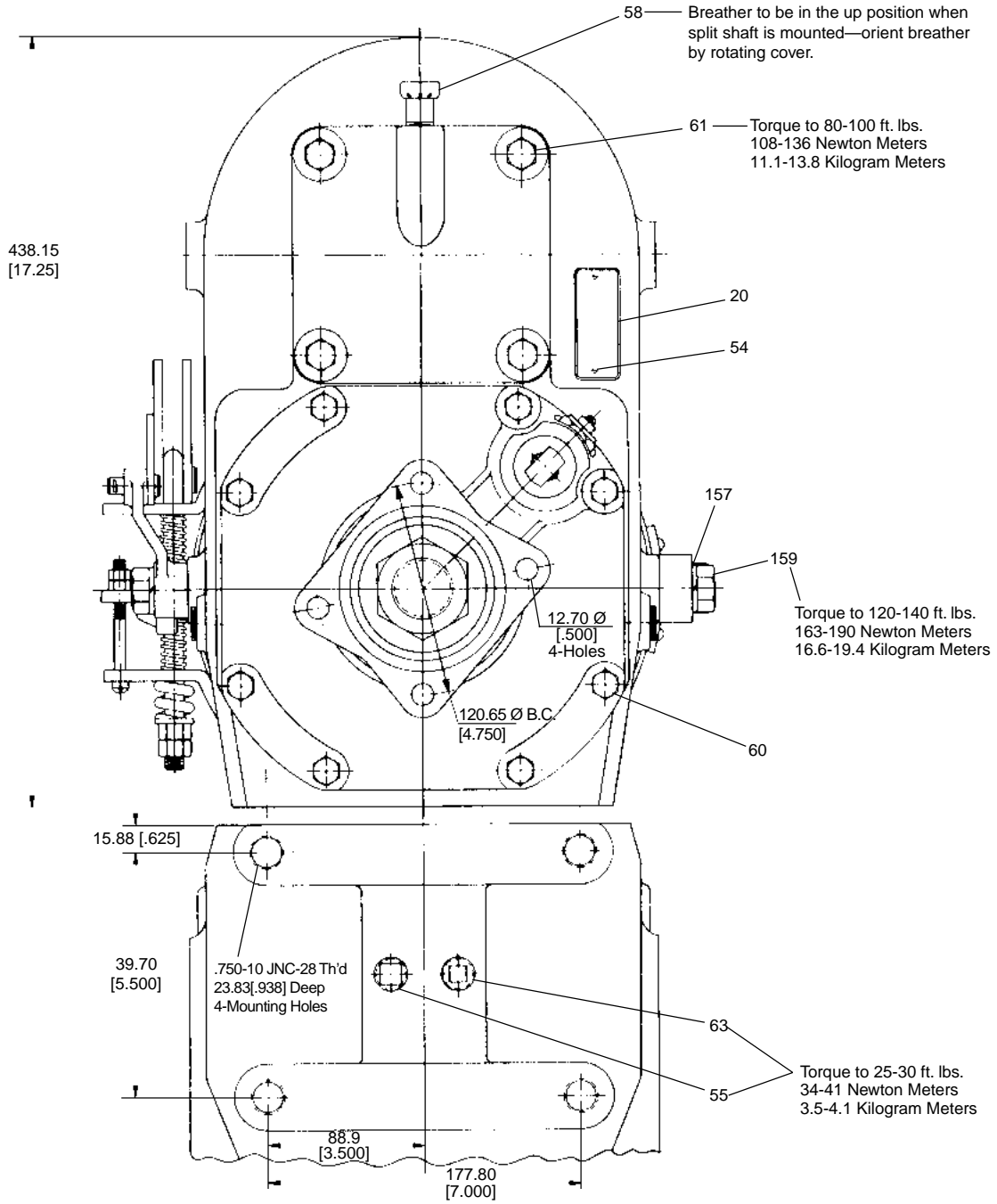

Bill of Materials

Item	Part Number	Description	Quantity
1	1-P-212	Housing	1
2	2-P-250	Gear, P.T.O. Drive	1
3	3-P-426	Drive Shaft, Output	1
4	3-P-428	Drive Shaft, Input	1
5	3-P-427	Drive Shaft, P.T.O.	1 or
	See Illust. Pg. 7 & 8	Shaft, Pump	1
8	5-P-626	Gear, Input Drive	1
9	21-P-185	Bearing Cover, Closed	1
10	21-P-65	Bearing Cover, Open	1 or
	See Illust. Pg. 7 & 8	Flange, Pump	1
13	28-P-35	Oil Seal - Standard Shaft	1
14	28-P-69	Oil Seal	2
15	35-P-17	Gasket	1
16	55-P-6-1	Shim, Plastic (.003")	A.R.
	55-P-6-2	Shim, Plastic (.010")	A.R.
18	55-P-19	Shim-Gasket	2
20	68-P-2	Name Plate	1
21	3-1-3431	Flange, Companion	1
22	4-1-3891	Flange, Brake (2-Lever Shift) (1-Air Shift)	Obsolete
	378808	Flange, Companion (Air Shift Only)	1
	328050X	Speed-O Gear & Bushing Assembly	1
26	45-P-7	Bushing, Speed-O Gear	1
27	378165	Bushing, Speed-O	1
	328919X	Shifter Cover Assembly, Lever Control	1
30	28-P-57	Oil Seal	1
31	34-P-100	Cover, Shifter	1
32	36-P-1	Eye Bolt	1
33	37-P-23	Spring, Shifter	1
34	378002	Poppet Ball (.438" Dia.)	1
	328916X	Shifter Shaft Assembly	1
37	11-P-141	Shaft	1
38	32-P-156	Fork	1
39	379110	Indicator Switch (Normally "ON")	1
40	50381-3	Jam Nut, Hex (.375"-24)	1
42	378076	Speed-O Gear-Drive	1
43	378077	Speed-O Gear-Driven	1
44	378151	Spacer, Speed-O	1
45	378156	Retaining Ring	1
46	378160	Gasket (.015")	2
48	378161	Gasket (.015")	1
49	378162	Nut, Hex (1.375"-12)	2
50	378163	Nut, Hex (1.125"-12)	1
51	378176	Hi-Pro Feather Key	1
52	378309	Gasket, Dust Cap	1
54	378422	Drive Screw	2
55	378507	Drain Plug, Magnetic (.500"-14)	1
56	378511	Sleeve Nut	1
57	378512	Dust Cap	1
58	378513	Pressure Relief Fitting	1
60	378431-14	Capscrew, Hex Head (.375"-18 x 1.50")	8
61	378433-14	Capscrew, Hex Head (.500"-13 x 1.50")	8
62	378553	Retaining Ring	2
63	379064	Pipe Plug, Patched (.500"-14 NPTF)	3
64	550026	Ball Bearing (309)	1

N.S. — Not Shown

A.R. — As Required

Continued Next Page



Item	Part Number	Description	Quantity
66	550311	Bearing, Ball (209)	1
67	550508	Bearing, Needle (162416)	1
68	550509	Bearing, Ball (112)	1
69	560945	Bearing Cone (33880)	2
70	560946	Bearing Cup (33821)	2
	328866X	Brake Parts	1
123	37P-28	Spring	2
124	38-P-29	Spring, Cushion	1
125	37-P-30	Spring, Support	1
126	378514	Band Cam	2
128	378515	Band Adj. Rod	1
129	378519	Support Bracket	1
130	378520	Support Quadrant	1
131	378521	Anchor Bar	1
132	378523	Band Cam Adj. Rod Pin	1
134	378524	Support Screw	1
135	378529	Flat Washer	1
136	500014-13	Clevis Pin (.375" Dia. x .812")	1
137	500023-2	Cotter Pin (.094" Dia. x .625")	1
138	500023-5	Cotter Pin (.094" Dia. x 1.00")	1
140	500370-1	Nut, Hex (.250"-20)	2
141	500370-4	Nut, Hex (.438"-14)	2
142	500486-19	Screw, Adjusting (.250"-20 x 2.750")	1
143	328361X	Band & Lining Ass'y	1
	378525	Band Support	1
	378526	Band End	Obsolete
147	378527	Band	Obsolete
148	378528	Band Lining	Obsolete
	500193-7	Rivet, Flat Head	Obsolete
	500193-9	Rivet, Flat Head	Obsolete
	500193-8	Rivet, Flat Head	Obsolete
	328867X	BRAKE PARTS	
154	378522	Brake Drum	Obsolete
155	378550	Capscrew, Hex Head (.500"-20 x 1.875")	Obsolete
156	500357-13	Lockwasher (.500" I.D.)	Obsolete
157	500357-14	Lockwasher (.562" I.D.)	Obsolete
158	500381-5	Nut, Hex (.500"-20)	Obsolete
159	500401-15	Capscrew, Hex Head (.562"-12 x 1.625")	Obsolete
	328751X	Indicator Light Installation Kit	1 or
	328388-30X	Air-o-matic Installation Kit	1
	328948-10X	Gasket And Installation Instructions	1
		SERVICE KITS	
	328267	Gasket & Seal Kit	
	328390-80X	Air Shift Filed Conversion Kit	

N.S. — Not Shown

A.R. — As Required

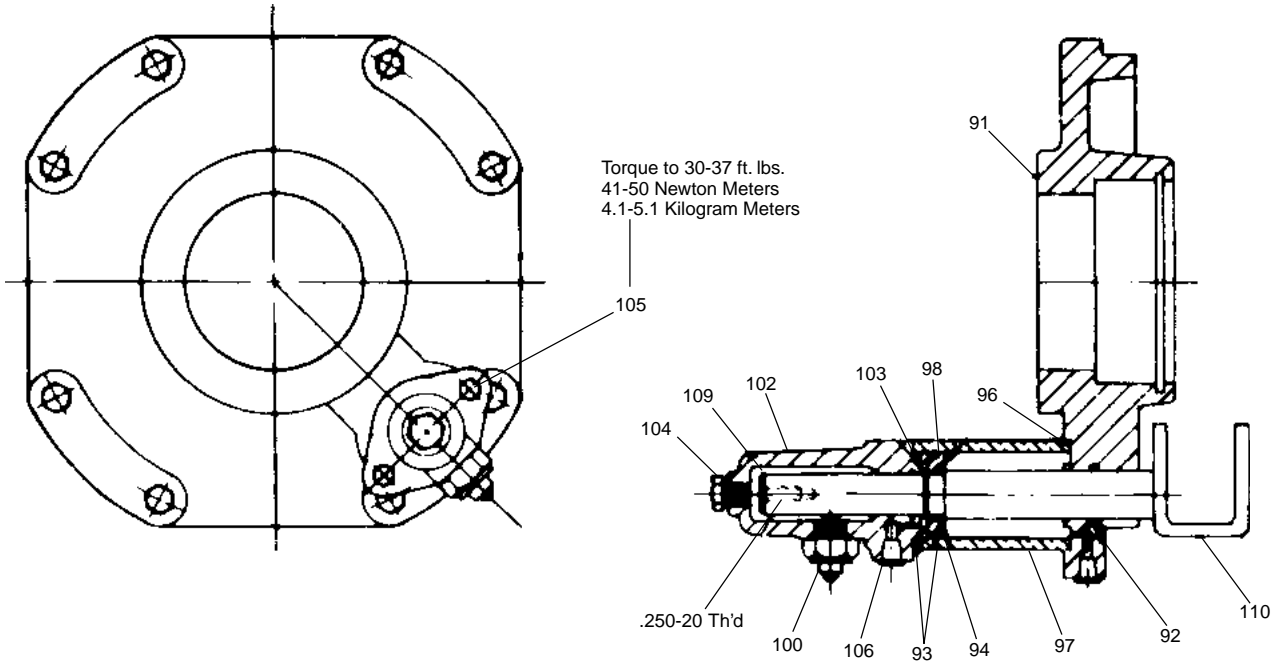

Item	Part Number	Description	Quantity
	328918X	SHIFTER COVER ASSEMBLY, Air Shift	1
91	21-P-186	Bearing Cover	1
92	28-P-59	O-Ring	1
93	28-P-61	O-Ring	2
94	28-P-71	O-Ring	2
96	35-P-16	Gasket	1
97	65-P-5	Cylinder Body	1
98	66-P-6	Piston	1
100	378969	Indicator Switch (Normally "OFF")	1
102	379234	Cylinder Cover	1
103	378471	Retaining Ring	1
104	379045	Breather	1
105	378431-30	Cap screw, Hex Head (.375"-16.4.00")	2
106	500897-3	Plug, Shipping	2
	328917X	Shifter Shaft Assembly	1
109	11-P-142	Shaft	1
110	32-P-156	Fork	1

**Pump Assembly "K"
 S.A.E. Class "B" 2 or 4 Bolt**

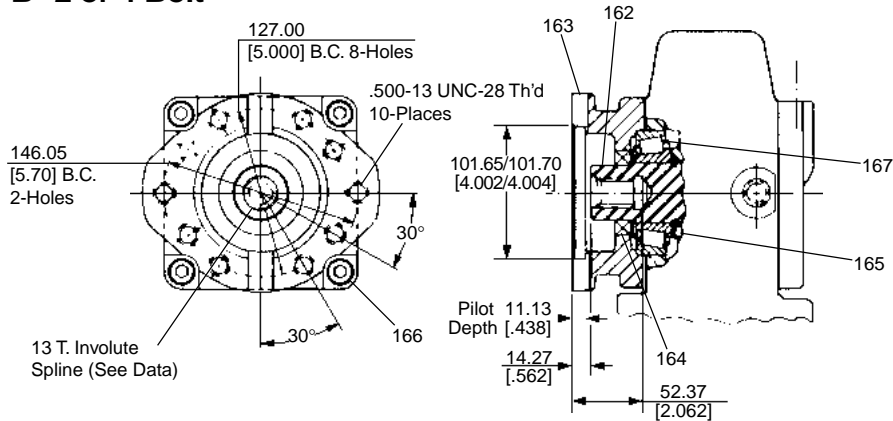

Item	Part Number	Description	Quantity
		PUMP ASSEMBLY "K"	
162	3-P-327	Shaft, Pump	1
163	21-P-163	Flange, Pump	1
164	28-P-37	Oil Seal	1
165	378215	Retaining Ring	1
166	378450-8	Screw, Hex Socket Head (.500"-13 x 1.50")	4
167	560944	Bearing Cone	1

**Pump Assembly "U"
 S.A.E. Class "C" 2 Bolt**

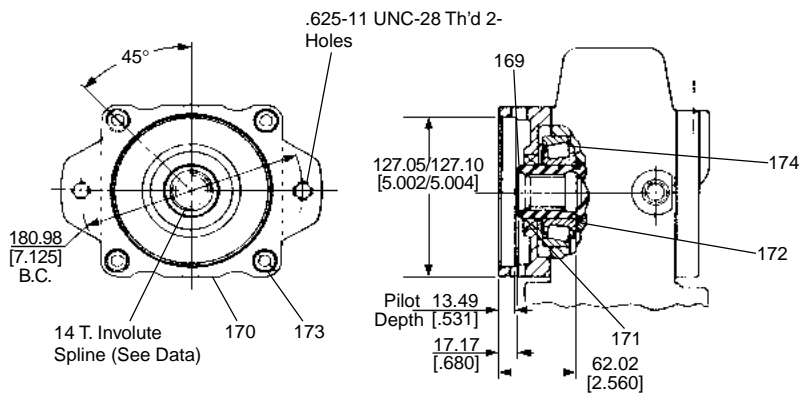

Item	Part Number	Description	Quantity
		PUMP ASSEMBLY "U"	
169	3-P-300	Shaft, Pump	1
170	21-P-382	Flange, Pump	1
171	28-P-37	Oil Seal	1
172	378215	Retaining Ring	1
173	378450-8	Screw, Hex Socket Head (.500"-13 x 1.50")	4
174	560944	Bearing Cone	1

**Pump Assembly "S"
 S.A.E. Class "C" 4 Bolt**

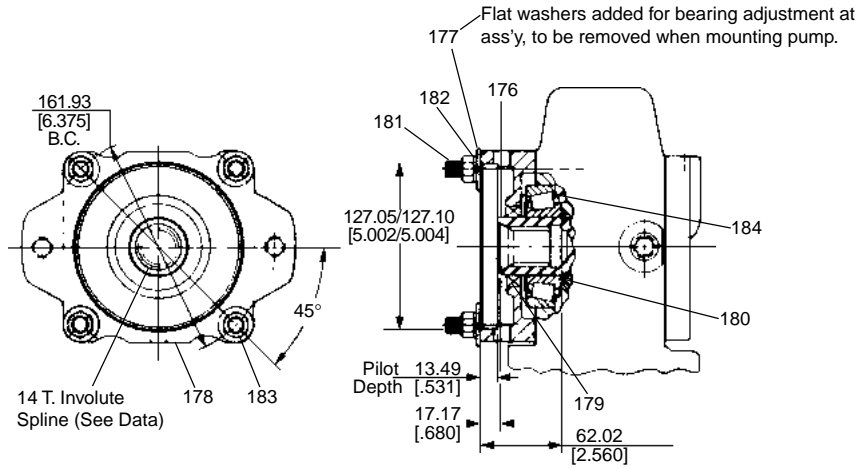

Item	Part Number	Description	Quantity
PUMP ASSEMBLY "S"			
176	3-P-300	Shaft, Pump	1
177	500365-37	Flat Washer	1
178	21-P-382	Flange, Pump	1
179	28-P-37	Oil Seal	1
180	378215	Retaining Ring	1
181	379056-47	Stud (.500"-13 & .500"-20 x 3.75")	4
182	500356-13	Lock Washer (.500" Dia.)	4
183	500381-5	Nut, Hex (.500"-20)	4
184	560944	Bearing Cone	1

Model Number Designation

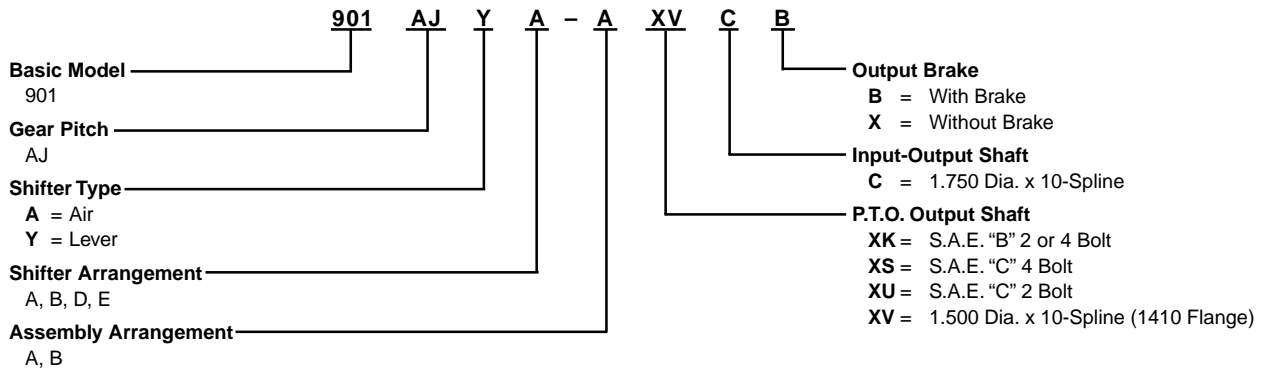

Assembly Arrangements

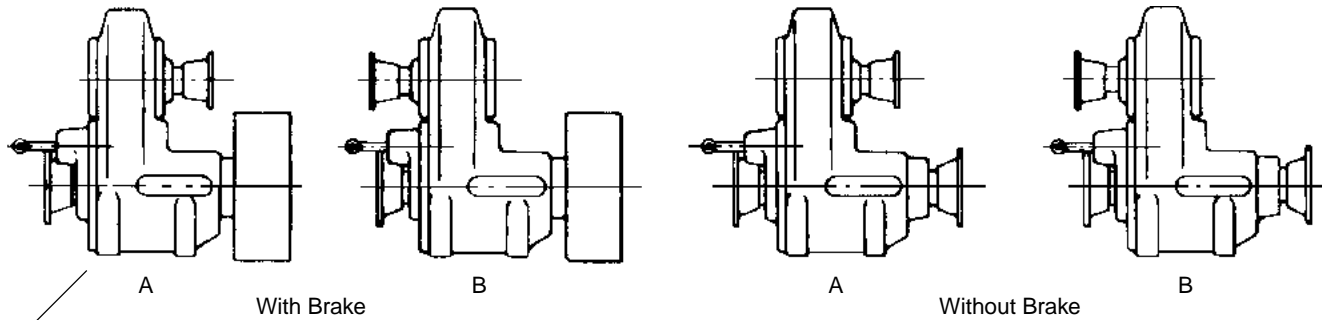

Ass'y A is not available with pump flange (brake interference).

Shifter Arrangements

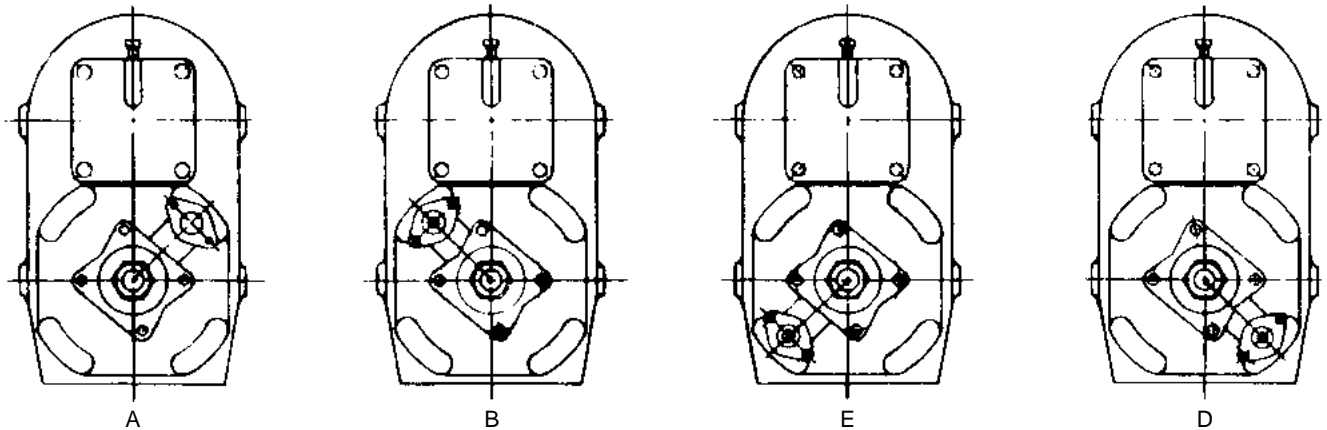

Offer of Sale

The items described in this document and other documents or descriptions provided by Parker Hannifin Corporation, its subsidiaries and its authorized distributors are hereby offered for sale at prices to be established by Parker Hannifin Corporation, its subsidiaries and its authorized distributors. This offer and its acceptance by any customer ("Buyer") shall be governed by all of the following Terms and Conditions. Buyer's order for any such items, when communicated to Parker Hannifin Corporation, its subsidiary or an authorized distributor ("Seller") verbally or in writing, shall constitute acceptance of this offer.

1. Terms and Conditions of Sale: All descriptions, quotations, proposals, offers, acknowledgments, acceptances and sales of Seller's products are subject to and shall be governed exclusively by the terms and conditions stated herein. Buyer's acceptance of any offer to sell is limited to these terms and conditions. Any terms or conditions in addition to, or inconsistent with those stated herein, proposed by Buyer in any acceptance of an offer by Seller, are hereby objected to. No such additional, different or inconsistent terms and conditions shall become part of the contract between Buyer and Seller unless expressly accepted in writing by Seller. Seller's acceptance of any offer to purchase by Buyer is expressly conditional upon Buyer's assent to all the terms and conditions stated herein, including any terms in addition to, or inconsistent with those contained in Buyer's offer. Acceptance of Seller's products shall in all events constitute such assent.

2. Payment: Payment shall be made by Buyer net 30 days from the date of delivery of the items purchased hereunder. Amounts not timely paid shall bear interest at the maximum rate permitted by law for each month or portion thereof that the Buyer is late in making payment. Any claims by Buyer for omissions or shortages in a shipment shall be waived unless Seller receives notice thereof within 30 days after Buyer's receipt of the shipment.

3. Delivery: Unless otherwise provided on the face hereof, delivery shall be made F.O.B. Seller's plant. Regardless of the method of delivery, however, risk of loss shall pass to Buyer upon Seller's delivery to a carrier. Any delivery dates shown are approximate only and Seller shall have no liability for any delays in delivery.

4. Warranty: Seller warrants that the items sold hereunder shall be free from defects in material or workmanship for a period of:

(A) All Power Take-Off units one (1) year from date of installation.

(B) Except 267, 277, 278, 242, 244, 250, 251 and 859 series two (2) years from date of installation. **THIS WARRANTY COMPRISES THE SOLE AND ENTIRE WARRANTY PERTAINING TO ITEMS PROVIDED HEREUNDER. SELLER MAKES NO OTHER WARRANTY, GUARANTEE, OR REPRESENTATION OF ANY KIND WHATSOEVER. ALL OTHER WARRANTIES, INCLUDING BUT NOT LIMITED TO, MERCHANTABILITY AND FITNESS FOR PURPOSE, WHETHER EXPRESS, IMPLIED, OR ARISING BY OPERATION OF LAW, TRADE USAGE, OR COURSE OF DEALING ARE HEREBY DISCLAIMED. NOTWITHSTANDING THE FOREGOING, THERE ARE NO WARRANTIES WHATSOEVER ON ITEMS BUILT OR ACQUIRED WHOLLY OR PARTIALLY, TO BUYER'S DESIGNS OR SPECIFICATIONS.**

5. Limitation Of Remedy: SELLER'S LIABILITY ARISING FROM OR IN ANY WAY CONNECTED WITH THE ITEMS SOLD OR THIS CONTRACT SHALL BE LIMITED EXCLUSIVELY TO REPAIR OR REPLACEMENT OF THE ITEMS SOLD OR REFUND OF THE PURCHASE PRICE PAID BY BUYER, AT SELLER'S SOLE OPTION. IN NO EVENT SHALL SELLER BE LIABLE FOR ANY INCIDENTAL, CONSEQUENTIAL OR SPECIAL DAMAGES OF ANY KIND OR NATURE WHATSOEVER, INCLUDING BUT NOT LIMITED TO LOST PROFITS ARISING FROM OR IN ANY WAY CONNECTED WITH THIS AGREEMENT OR ITEMS SOLD HEREUNDER, WHETHER ALLEGED TO ARISE FROM BREACH OF CONTRACT, EXPRESS OR IMPLIED WARRANTY, OR IN TORT, INCLUDING WITHOUT LIMITATION, NEGLIGENCE, FAILURE TO WARN OR STRICT LIABILITY.

6. Changes, Reschedules and Cancellations: Buyer may request to modify the designs or specifications for the items sold hereunder as well as the quantities and delivery dates thereof, or may request to cancel all or part of this order, however, no such requested modification or cancellation shall become part of the contract between Buyer and Seller unless accepted by Seller in a written amendment to this Agreement. Acceptance of any such requested modification or cancellation shall be at Seller's discretion, and shall be upon such terms and conditions as Seller may require.

7. Special Tooling: A tooling charge may be imposed for any special tooling, including without limitation, dies, fixtures, molds and patterns, acquired to manufacture items sold pursuant to this contract. Such special tooling shall be and remain Seller's property notwithstanding payment of any charges by Buyer. In no event will Buyer acquire any interest in apparatus belonging to Seller which is utilized in the manufacture of the items sold hereunder, even if such apparatus has been specially converted or adapted for such manufacture and notwithstanding any charges paid by Buyer. Unless otherwise agreed, Seller shall

have the right to alter, discard or otherwise dispose of any special tooling or other property in its sole discretion at any time.

8. Buyer's Property: Any designs, tools, patterns, materials, drawings, confidential information or equipment furnished by Buyer or any other items which become Buyer's property, may be considered obsolete and may be destroyed by Seller after two (2) consecutive years have elapsed without Buyer placing an order for the items which are manufactured using such property, Seller shall not be responsible for any loss or damage to such property while it is in Seller's possession or control.

9. Taxes: Unless otherwise indicated on the face hereof, all prices and charges are exclusive of excise, sales, use, property, occupational or like taxes which may be imposed by any taxing authority upon the manufacture, sale or delivery of the items sold hereunder. If any such taxes must be paid by Seller or if Seller is liable for the collection of such tax, the amount thereof shall be in addition to the amounts for the items sold. Buyer agrees to pay all such taxes or to reimburse Seller therefore upon receipt of its invoice. If Buyer claims exemption from any sales, use or other tax imposed by any taxing authority, Buyer shall save Seller harmless from and against any such tax, together with any interest or penalties thereon which may be assessed if the items are held to be taxable.

10. Indemnity For Infringement of Intellectual Property Rights: Seller shall have no liability for infringement of any patents, trademarks, copyrights, trade dress, trade secrets or similar rights except as provided in this Part 10. Seller will defend and indemnify Buyer against allegations of infringement of U.S. Patents, U.S. Trademarks, copyrights, trade dress and trade secrets (hereinafter 'Intellectual Property Rights'). Seller will defend at its expense and will pay the cost of any settlement or damages awarded in an action brought against Buyer based on an allegation that an item sold pursuant to this contract infringes the Intellectual Property Rights of a third party. Seller's obligation to defend and indemnify Buyer is contingent on Buyer notifying Seller within ten (10) days after Buyer becomes aware of such allegations of infringement, and Seller having sole control over the defense of any allegations or actions including all negotiations for settlement or compromise. If an item sold hereunder is subject to a claim that it infringes the Intellectual Property Rights of a third party, Seller may, at its sole expense and option, procure for Buyer the right to continue using said item, replace or modify said item so as to make it noninfringing, or offer to accept return of said item and return the purchase price less a reasonable allowance for depreciation. Notwithstanding the foregoing, Seller shall have no liability for claims of infringement based on information provided by Buyer, or directed to items delivered hereunder for which the designs are specified in whole or part by Buyer, or infringements resulting from the modification, combination or use in a system of any item sold hereunder. The foregoing provisions of this Part 10 shall constitute Seller's sole and exclusive liability and Buyer's sole and exclusive remedy for infringement of Intellectual Property Rights.

If a claim is based on information provided by Buyer or if the design for an item delivered hereunder is specified in whole or in part by Buyer, Buyer shall defend and indemnify Seller for all costs, expenses or judgments resulting from any claim that such item infringes any patent, trademark, copyright, trade dress, trade secret or any similar right.

11. Force Majeure: Seller does not assume the risk of and shall not be liable for delay or failure to perform any of Seller's obligations by reason of circumstances beyond the reasonable control of Seller (hereinafter 'Events of Force Majeure'). Events of Force Majeure shall include without limitation, accidents, acts of God, strikes or labor disputes, acts, laws, rules or regulations of any government or government agency, fires, floods, delays or failures in delivery of carriers or suppliers, shortages of materials and any other cause beyond Seller's control.

12. Entire Agreement/Governing Law: The terms and conditions set forth herein, together with any amendments, modifications and any different terms or conditions expressly accepted by Seller in writing, shall constitute the entire Agreement concerning the items sold, and there are no oral or other representations or agreements which pertain thereto. This Agreement shall be governed in all respects by the law of the State of Ohio. No actions arising out of the sale of the items sold hereunder or this Agreement may be brought by either party more than two (2) years after the cause of action accrues.

9/01-P



Parker Hannifin Corporation
Chelsea Products Division
8225 Hacks Cross Road
Olive Branch, Mississippi 38654 USA
Tel: (662) 895-1011
Fax: (662) 895-1019
www.parker.com/chelsea

FP 01/02 2M